



The Future of Analog IC Technology™

EV2361DK/DQ-00A

2A, 1.4MHz Step-Down Converter Evaluation Board

DESCRIPTION

The EV2361DK/DQ-00A is the evaluation board for the MP2361, a monolithic step down switch mode converter with a built in internal power MOSFET. The MP2361 achieves 2A continuous output current over a wide input supply range with excellent load and line regulation.

Current mode operation provides fast transient response and eases loop stabilization.

Fault condition protection includes cycle-by-cycle current limiting and thermal shutdown. In shutdown mode the regulator draws 20µA of supply current. Programmable soft-start minimizes the inrush supply current and the output overshoot at initial startup.

The MP2361 requires a minimum number of readily available standard external components.

FEATURES

- 2A Output Current with QFN Package
- Up to 90% Efficiency
- 20µA Shutdown Mode
- Fixed 1.4MHz Frequency
- Thermal Shutdown
- Cycle-by-Cycle Over Current Protection
- Wide 4.75V to 23V Operating Input Range
- Output Adjustable from 0.92V to 16V
- Programmable Under Voltage Lockout

APPLICATIONS

- Distributed Power Systems
- Set Top Boxes
- DSL Modems
- Pre-Regulator for Linear Regulators

"MPS" and "The Future of Analog IC Technology" are Trademarks of Monolithic Power Systems, Inc.

ELECTRICAL SPECIFICATIONS

Parameter	Symbol	Value	Units
Input Voltage	V _{IN}	4.75 to 23	V
Output Voltage	V _{OUT}	3.3	V
Output Current ⁽¹⁾	I _{OUT}	2	A

Note:

- 1) The maximum output current may be less than 2A if V_{OUT}>60% of V_{IN}.

EV2361DK/DQ-00A EVALUATION BOARD

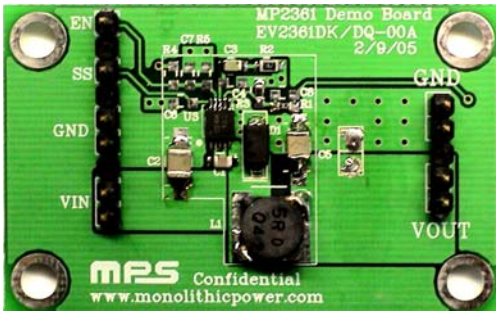

(L x W x H) 2.1" x 1.3" x 0.4"
(5.3cm x 3.3cm x 1.0cm)

Board Number	MPS IC Number
EV2361DK/DQ-00A	MP2361DK/DQ

Efficiency vs Load Current

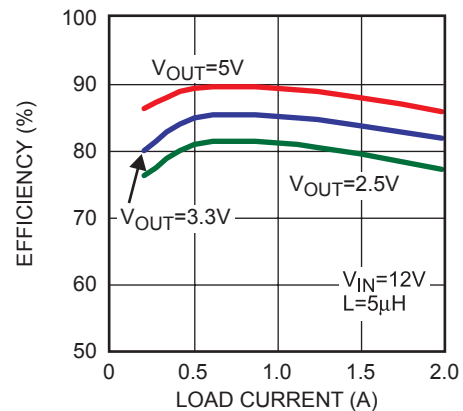

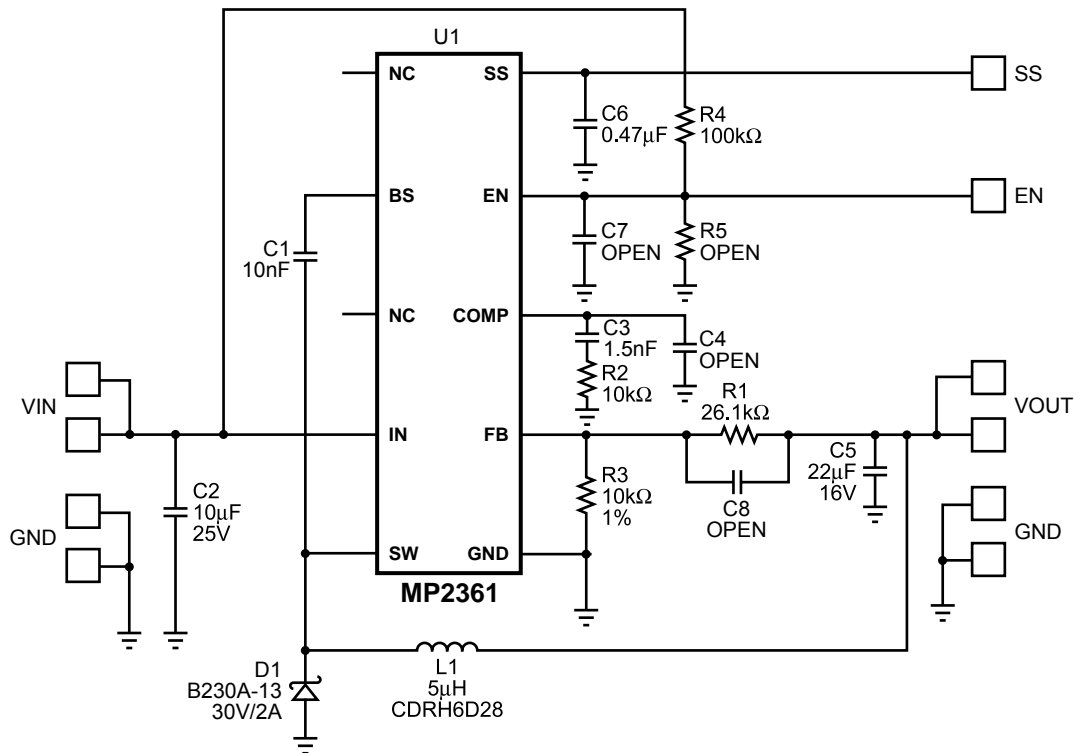
EVALUATION BOARD SCHEMATIC

EV2361DK/DQ-00A BILL OF MATERIALS

Qty	Ref	Value	Description	Package	Manufacturer	Manufacturer P/N
1	C1	10nF	Ceramic Capacitor, 50V, X7R	SM0805	TDK	C2012X7R1H103K
1	C2	10µF	Ceramic Capacitor 25V, X7R	SM1210	TDK	C3225X7R1E106M
1	C3	1.5nF	Ceramic Capacitor 50V, X7R	SM0805	Panasonic	ECJ-2VB1H152K
3	C4, C7, C8	OPEN	Do Not Stuff			
1	C5	22µF	Ceramic Capacitor 16V, X5R	SM1210	TDK	C3225X5R1C226M
1	C6	0.47µF	Ceramic Capacitor 25V, X7R	SM0805	TDK	C2012X7R1E474K
1	D1		Schottky Diode, 30V, 2A	SMA	Diodes Inc	B230A-13
1	L1	5µH	Inductor, 2.4A	SMD	Sumida	CDRH6D28-5R0NC
1	R1	26.1kΩ	Resistor, 1%	SM0805	Panasonic	ERJ-6ENF2610V
2	R2, R3	10kΩ	Resistor, 1%	SM0805	Panasonic	ERJ-6ENF1002V
1	R4	100kΩ	Resistor, 5%	SM0805	Panasonic	ERJ-6GEYJ104V
1	R5	OPEN	Do Not Stuff			
1	U1		Step-Down Converter	QFN10/ MSOP10	MPS	MP2361DQ/MP2361DK

PRINTED CIRCUIT BOARD LAYOUT

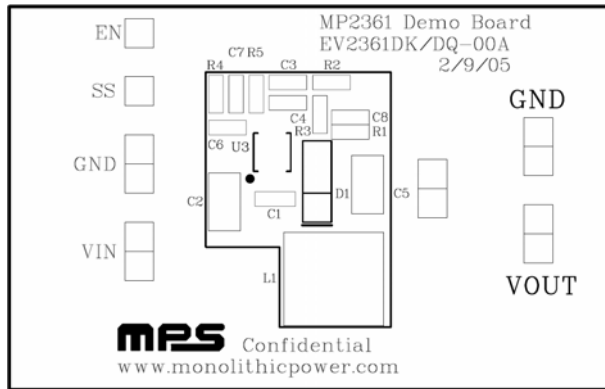

Figure 1—Top Silk Layer

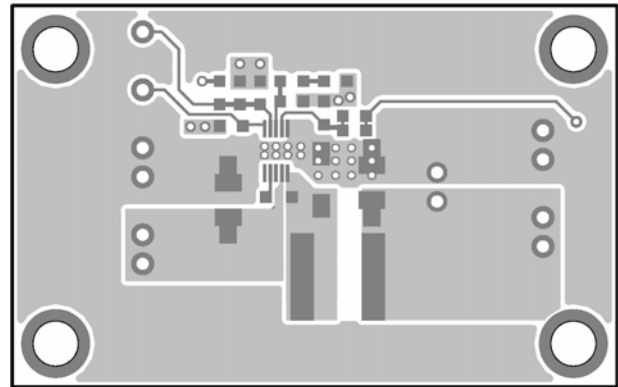

Figure 2—Top Layer

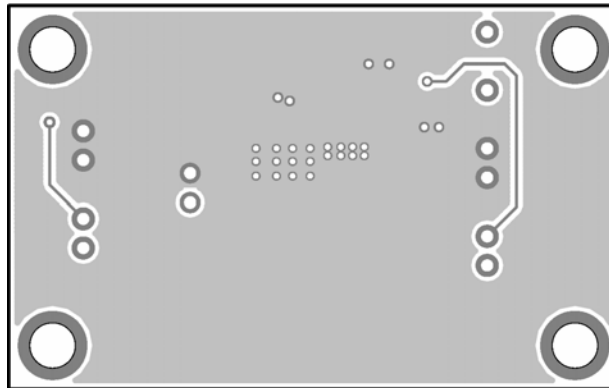

Figure 3—Bottom Layer

QUICK START GUIDE

1. Connect the positive terminal of the load to the VOUT pins, and the negative terminal of the load to the GND pins
2. Preset the power supply output to 4.75V to 23V and turn off the power supply.
3. Connect the positive terminal of the power supply output to the VIN pin and the negative terminal of the power supply output to the GND pin
4. Turn the power supply on. The MP2361 will automatically startup.
5. To use the Enable function, apply a digital input to EN pin. Drive EN higher than 2.5V to turn on the regulator, drive EN less than 0.7V to turn it off.
6. An input under voltage lockout (UVLO) function can be implemented by the addition of a resistor divider R4 and R5.

The EN threshold is 2.5V, so V_{IN} UVLO threshold is: $\left(1 + \frac{R4}{R5}\right) \times 2.5V$.

NOTICE: The information in this document is subject to change without notice. Please contact MPS for current specifications. Users should warrant and guarantee that third party Intellectual Property rights are not infringed upon when integrating MPS products into any application. MPS will not assume any legal responsibility for any said applications.